



# Standard Test Method for Abrasion Resistance of Leather (Rotary Platform, Abraser Method)<sup>1</sup>

This standard is issued under the fixed designation D7255; the number immediately following the designation indicates the year of original adoption or, in the case of revision, the year of last revision. A number in parentheses indicates the year of last reapproval. A superscript epsilon ( $\epsilon$ ) indicates an editorial change since the last revision or reapproval.

## 1. Scope

1.1 This test method covers the determination of the abrasion resistance of leather using the rotary platform abraser.

NOTE 1—This test method is similar but not equivalent to ISO 17076-1, and results should not be directly compared between the two methods.

1.2 The values stated in SI units are to be regarded as standard. No other units of measurement are included in this standard.

1.3 *This standard does not purport to address all of the safety concerns, if any, associated with its use. It is the responsibility of the user of this standard to establish appropriate safety and health practices and to determine the applicability of regulatory limitations prior to use.*

## 2. Referenced Documents

2.1 *ASTM Standards:*<sup>2</sup>

[D1517 Terminology Relating to Leather](#)

[D1610 Practice for Conditioning Leather and Leather Products for Testing](#)

[D2813 Practice for Sampling Leather for Physical and Chemical Tests](#)

[G195 Guide for Conducting Wear Tests Using a Rotary Platform Abraser](#)

2.2 *Other Standards:*<sup>3</sup>

[ISO 17076-1 Leather-Determination of abrasion resistance Part 1-Taber method](#)

## 3. Terminology

3.1 *Definitions:*

3.1.1 *abraser*—a wear testing instrument, also referred to as a rotary platform tester or abrader.

<sup>1</sup> This test method is under the jurisdiction of ASTM Committee D31 on Leather and is the direct responsibility of Subcommittee D31.07 on Physical Properties.

Current edition approved April 1, 2014. Published May 2014. Originally approved in 2006. Last previous edition approved in 2006 as D7255-06<sup>ε1</sup>. DOI: 10.1520/D7255-14.

<sup>2</sup> For referenced ASTM standards, visit the ASTM website, [www.astm.org](http://www.astm.org), or contact ASTM Customer Service at [service@astm.org](mailto:service@astm.org). For *Annual Book of ASTM Standards* volume information, refer to the standard's Document Summary page on the ASTM website.

<sup>3</sup> Available from American National Standards Institute (ANSI), 25 W. 43rd St., 4th Floor, New York, NY 10036, <http://www.ansi.org>.

3.1.2 *abrasion*—the wearing away of any part of a material by rubbing against another surface.

3.1.3 *abrasion cycle*—in *abrasion testing*, one or more movements of the abradant across a material surface, or the material surface across the abradant, that permits a return to its starting position. In the case of the rotary platform test method, it consists of one complete rotation of the specimen.

3.1.4 *durability*—the ability to withstand deterioration or wear out in use, including the effects of abrasion.

3.1.5 *resurface*—the preparation of an abrasive wheel on a resurfacing disk or diamond tool wheel refacer, prior to use in testing.

3.2 For definitions of other leather terms used in this test method, refer to Terminology [D1517](#).

## 4. Summary of Test Method

4.1 A specimen is abraded using rotary rubbing action under controlled conditions of pressure and abrasive action. The test specimen, mounted on a turntable platform, turns on a vertical axis, against the sliding rotation of two abrading wheels. One abrading wheel rubs the specimen outward toward the periphery and the other, inward toward the center. The resulting abrasion marks form a pattern of crossed arcs over an area of approximately 30 cm<sup>2</sup>. Resistance to abrasion is evaluated by visual inspection of damage to the specimen or change in weight, as described in Section 14.

## 5. Significance and Use

5.1 The resistance of leather to abrasion, as measured on a testing machine in the laboratory, is generally only one of several factors contributing to wear performance or durability as experienced in the actual use of the material. While “abrasion resistance” (often stated in terms of the number of abrasion cycles) and “durability” are frequently related, the relationship varies with different end uses and different factors may be necessary in any calculation of predicted durability from specific abrasion data. This test method provides a comparative ranking of material performance, which can be used as an indication of relative end-use performance.

5.2 The resistance of leather to abrasion may be affected by factors including test conditions, type of abradant, pressure

between the specimen and abrasant, mounting or tension of the specimen, and type, kind, or amount of finishing materials.

5.3 Abrasion tests utilizing the rotary platform abraser may be subject to variation due to changes in the abrasant during specific tests. Depending on abrasant type and test specimen, the wheel surface may change (that is, become clogged) due to the pick up of finishing or other materials from test specimens and must be resurfaced at regularly defined intervals.

5.4 The measurement of the relative amount of abrasion may also be affected by the method of evaluation and may be influenced by the judgment of the operator.

**6. Apparatus**

6.1 *Rotary Platform Abraser*,<sup>4</sup> as described in Guide G195 and consisting of the elements described in 6.1.1 – 6.1.5 (see Fig. 1).

6.1.1 A turntable platform, which is removable, that includes a rubber pad, clamp plate and centrally located threaded post and nut. When testing flexible specimens, the platform will also include a clamping ring to secure the specimen to the turntable. The turntable is motor driven and mounted so as to produce a circular surface travel of an essentially flat specimen in the plane of its surface,

6.1.2 A motor capable of rotating the turntable platform at a speed of either  $72 \pm 2$  r/min for 110 V/60 Hz or  $60 \pm 2$  r/min for 230 V/50 Hz,

6.1.3 A pair of pivoted arms to which the abrasive wheels and accessory weights or counterweights are attached,

NOTE 2—Without auxiliary weights or counter weights applied, each arm will apply a load against the specimen of  $250 \pm 1$  g (exclusive of the mass of the wheel itself).

<sup>4</sup> Available from Taber® Industries, 455 Bryant Street, North Tonawanda, NY 14120.

6.1.4 A vacuum suction system and vacuum pickup nozzle to remove debris and abrasive particles from the specimen surface during testing. The height of the vacuum pickup nozzle shall be adjustable, and will have two openings – with one opening positioned between the two wheels and over the wear path and the other placed diametrically opposite. The distance between the axes of the two openings shall be  $76.0 \pm 1.0$  mm, and

6.1.5 A counter to record the number of cycles (revolutions) made by the turntable platform.

6.2 *Abrasive Wheels*,<sup>5</sup> which are attached to the free end of the pivoted arms, and are able to rotate freely about horizontal spindles. The abrasive wheels are either resilient or vitrified based, with both types of wheels consisting of hard particles embedded in a binder material and manufactured in different grades of abrasive quality.

6.2.1 Their internal faces shall be  $52.4 \pm 1.0$  mm apart and the hypothetical line through the two spindles shall be  $19.05 \pm 0.3$  mm away from the central axis of the turntable (see Fig. 2). When resting on the specimen, the wheels will have a peripheral engagement with the surface of the specimen, the direction of travel of the periphery of the wheels and of the specimen at the contacting portions being at acute angles, and the angles of travel of one wheel periphery being opposite to that of the other. Motion of the abrasive wheels, in opposite directions, is provided by rotation of the specimen and the associated friction there from.

6.2.2 The wheels shall be  $12.7 \pm 0.3$  mm thick and have an external diameter of  $51.9 \pm 0.5$  mm when new, and in no case less than 44.4 mm.

<sup>5</sup> The sole source of supply of the apparatus known to the committee at this time is Taber Industries, 455 Bryant Street, North Tonawanda, NY 14120. If you are aware of alternative suppliers, please provide this information to ASTM International Headquarters. Your comments will receive careful consideration at a meeting of the responsible technical committee,<sup>1</sup> which you may attend.

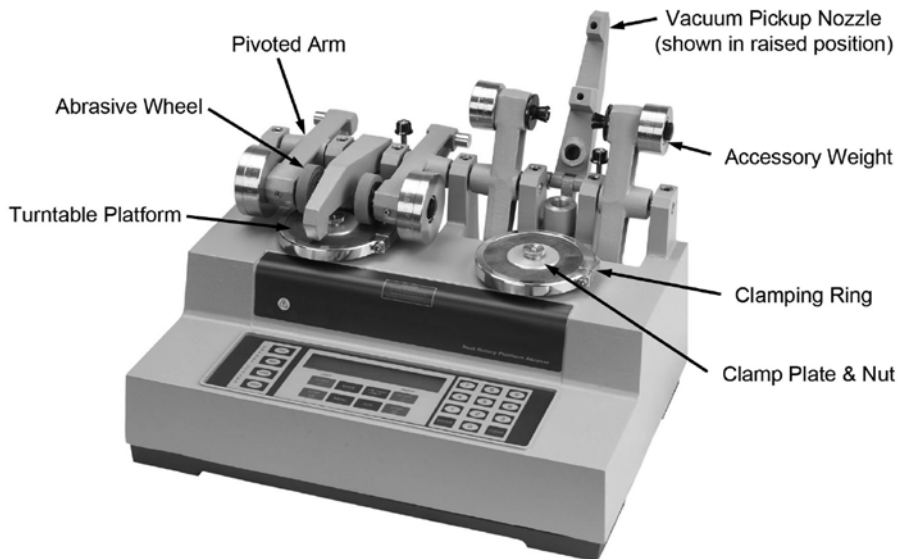

Note: Vacuum Suction System not shown

FIG. 1 Rotary Platform, Abraser

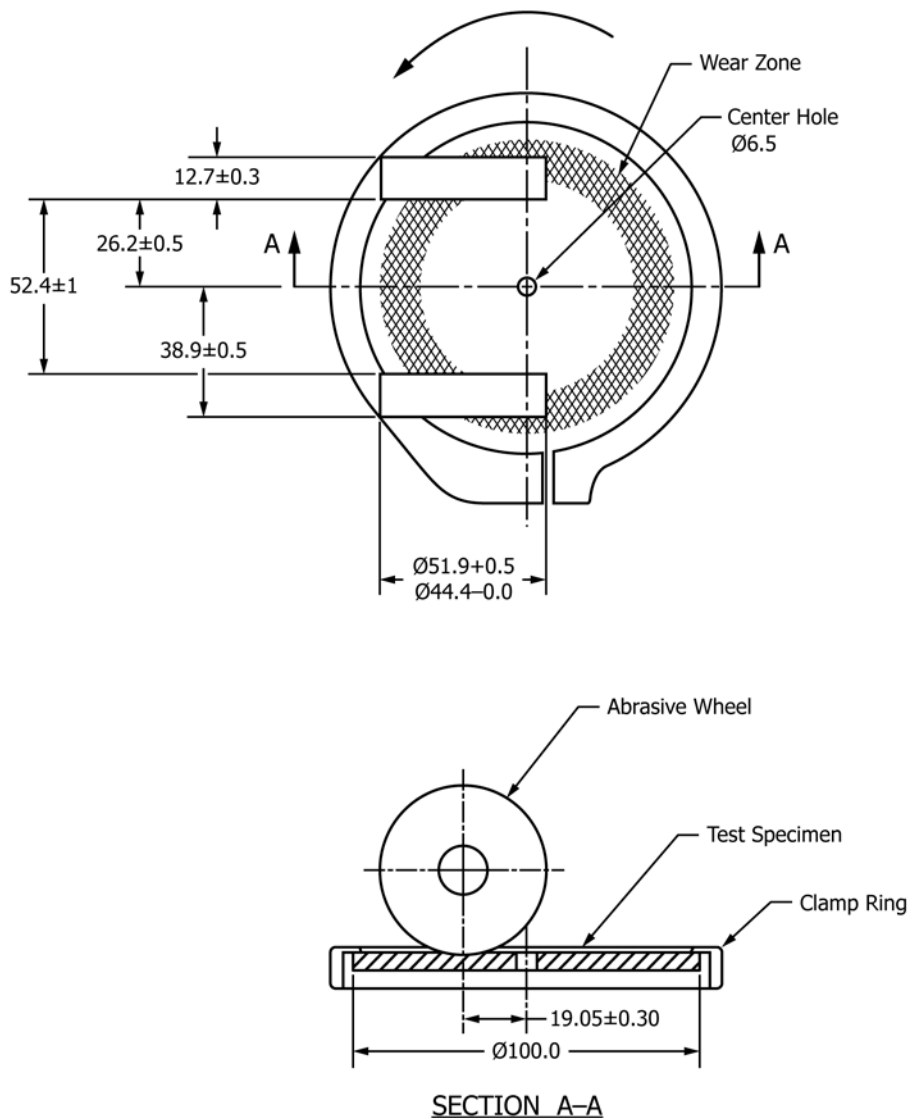

FIG. 2 Diagrammatic Arrangement of Apparatus

NOTE 3—The H-18 wheels typically produce a harsher abrasion than the CS-17 wheels, which produce a harsher abrasion than the CS-10 wheels.

NOTE 4—The S-35 Tungsten Carbide wheels include 1 mm pitch  $\times$  45° spiral pitch angle, helical teeth cut into its periphery. This wheel does not include hard particles embedded in a binder material, and typically produces severe cutting and abrasion.

6.2.3 Prior to testing, ensure the expiration date has not passed for resilient wheels. Follow the manufacturer’s recommended practice for breaking in new or resurfacing previously used wheel sets (see Section 10).

6.3 *Accessory Weights*, which can be attached to the pivoted abrader arms to increase the load against the specimen to 500 or 1000 g per wheel (exclusive of the mass of the wheel itself), see 11.1.6. Counterweight attachments of 125 or 175 g are available to reduce the load against the specimen, and can be used with or without the accessory weights.

6.4 *Auxiliary Apparatus:*

6.4.1 Resurfacing disc<sup>4</sup> (S-11), is used for resurfacing of resilient wheels.

6.4.2 A soft bristle brush, to remove loose particles from the surface of the specimen after testing.

6.4.3 Wheel refacer,<sup>4</sup> for resurfacing vitrified wheels or correcting out of round wheels.

6.4.4 Specimen mounting cards (S-36-1) or equivalent,<sup>4</sup> a 108 mm round mounting card with a 6.35 mm center hole and one side coated with pressure-sensitive adhesive used for mounting specimens. Use of the mounting card is not required when using a clamping ring.

7. Sampling

7.1 Take a lot sample as described in Practice D2813, or as agreed upon by the interested parties. Because leather is a natural product, the physical properties may vary depending on location on the hide, side or skin from which the test sample is